

ACCUD

ACCURATE MEASUREMENT



See full product range at: accud.com.au

Digital Screw Thread Micrometer



Series 333



© Copyright M Gamer Pty. Ltd. 2023

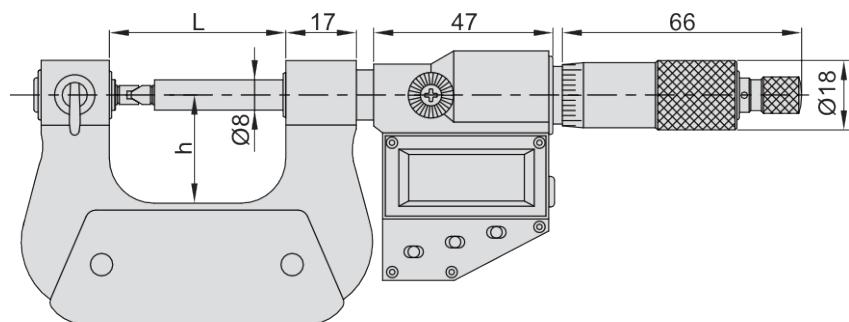

© Copyright M Gamer Pty. Ltd. 2023

Features

- Measure pitch diameter of screw threads
- Resolution 0.001mm/0.00005"
- Button: on/off, set, mm/inch, ABS/INC, data output
- Automatic power off
- Data output
- Non-rotating spindle
- Ratchet stop
- Supplied with 60° setting standards (except 333-001-01)
- Optional accessory: 55° setting standards

Specifications

Part No	Range	Micrometer Head Accuracy	h	L	Setting Standards
AC-333-001-01	0-25mm/0-1"	±4µm	26	42	-
AC-333-002-01	25-50mm/1-2"	±4µm	38	67	25mm
AC-333-003-01	50-75mm/2-3"	±5µm	50	92	50mm
AC-333-004-01	75-100mm/3-4"	±5µm	62	117.6	75mm
AC-333-005-01	100-125mm/4-5"	±6µm	70	143	100mm
AC-333-006-01	125-150mm/5-6"	±6µm	82	168	125mm
AC-333-007-01	150-175mm/6-7"	±7µm	94.5	192	150mm
AC-333-008-01	175-200mm/7-8"	±7µm	107	217	175mm