

# ACCUD

## ACCURATE MEASUREMENT



See full product range at: [accud.com.au](http://accud.com.au)

# Digital V-Anvil Micrometer

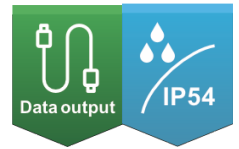

Series 334



## Features

Measure the outside diameter of cutting tools (such as taps, reamers, end mills) with 3 or 5 flutes

Resolution: 0.001mm/0.00005"

Button: on/off, set, mm/inch, ABS/INC, data output

Automatic power off, Ratchet stop

Data output

Carbide measuring faces

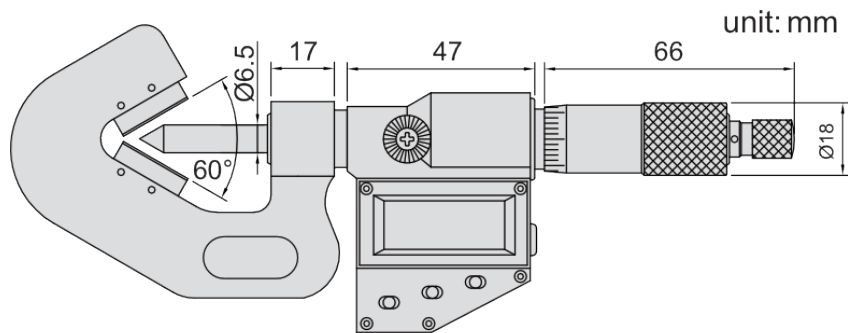

## Specifications

Part No	Range	Accuracy	Setting Standards	Type	Flutes
AC-334-015-01	1-15mm/0.04-0.6"	±4μm	5mm	A	3
AC-334-020-01	5-20mm/0.2-0.8"	±4μm	5mm	B	3
AC-334-025-55	5-25mm/0.2-1.0"	±4μm	5mm	B	5
AC-334-035-01	20-35mm/0.8-1.4"	±5μm	20mm	B	3
AC-334-045-55	25-45mm/1.0-1.8"	±5μm	25mm	B	5
AC-334-050-01	35-50mm/1.4-2.0"	±5μm	35mm	B	3
AC-334-065-55	45-65mm/1.8-2.6"	±6μm	50mm	B	5
AC-334-085-55	65-85mm/2.6-3.4"	±6μm	65mm	B	5
AC-334-105-55	85-105mm/3.3-4.2"	±6μm	85mm	B	5