

# ACCUD

## ACCURATE MEASUREMENT



See full product range at: [accud.com.au](http://accud.com.au)

# Dial Snap Gauge

Series 431



## Features

For quick Go/No-Go judgment of diameter of cylinders and shafts

Anvil retracting stroke: 3mm

Measuring force: 6–9N

Carbide measuring faces

Front edges of anvils are chamfered for easy workpiece insertion

Optional indicators:

--dial indicator, range 10mm, graduation 0.01mm (code 222-010-11)

--digital indicator, range 12.7mm/0.5", resolution 0.001mm/0.00005" (code 211-010-03)

--digital indicator, range 12.7mm/0.5", resolution 0.01mm/0.0005" (code 211-010-13)

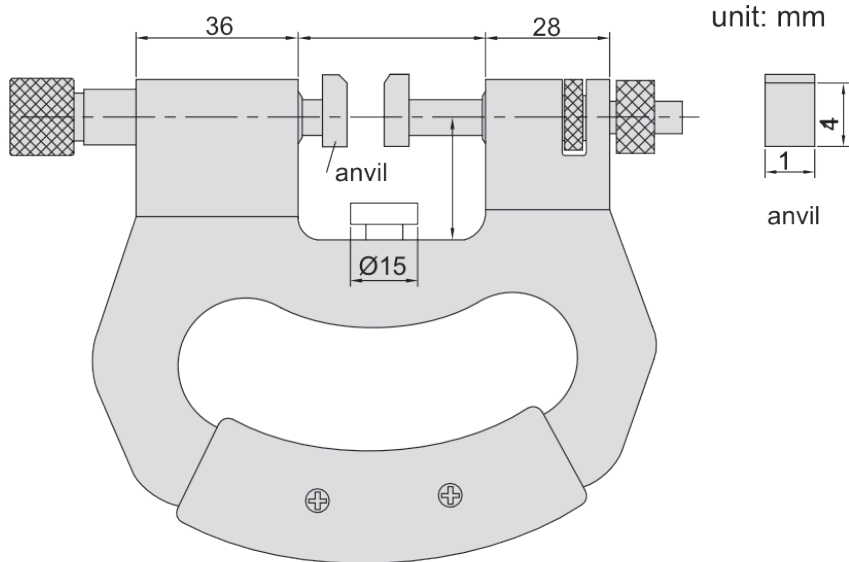

## Specifications

Part No	Range	a	h
AC-431-025-11	0-25mm	42	20
AC-431-050-11	25-50mm	69	33
AC-431-075-11	50-75mm	94	45
AC-431-100-11	75-100mm	119	58
AC-431-125-11	100-125mm	144	70
AC-431-150-11	125-150mm	169	83
AC-431-175-11	150-175mm	194	95
AC-431-200-11	175-200mm	219	107
AC-431-225-11	200-225mm	244	120
AC-431-250-11	225-250mm	269	132

Part No	Range	a	h
AC-431-275-11	250-275mm	294	145
AC-431-300-11	275-300mm	319	157